

IDENTIFICATION CHARTS

- Air Springs
- Brake Drums and Rotors
- Brake Shoe Kits
- Aluminium Wheels
- Differential Carriers



Meritor

**FOR
A WORLD
THAT'S
ALWAYS ON™**



IDENTIFICATION CHART #23-002

BRAKE DRUMS & ROTORS

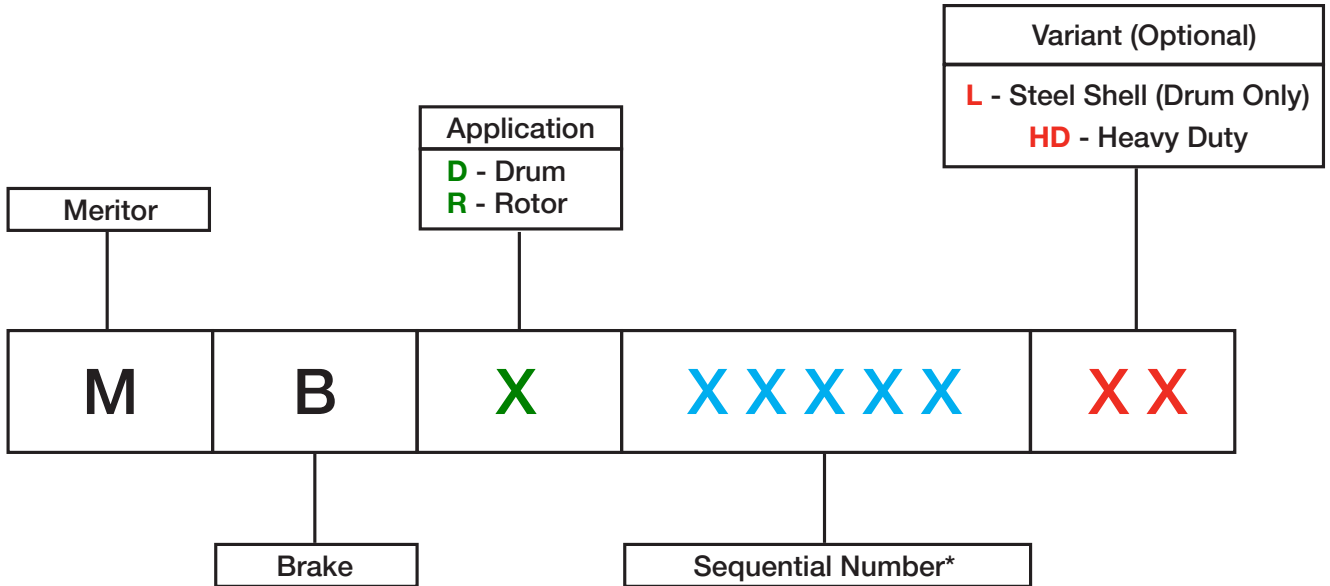

***Notes**

- Base number (without any suffix) refers to Cast Drums
- Sequential numbers may be related to industry standard numbers (e.g. MBD136L)

Revision:		
A	11 MAR 2022	ORIGINAL ISSUE

Meritor Heavy Vehicle Systems
50 Calarco Drive, Derrimut, VIC 3026 Australia



IDENTIFICATION CHART #23-003

BRAKE SHOE KIT

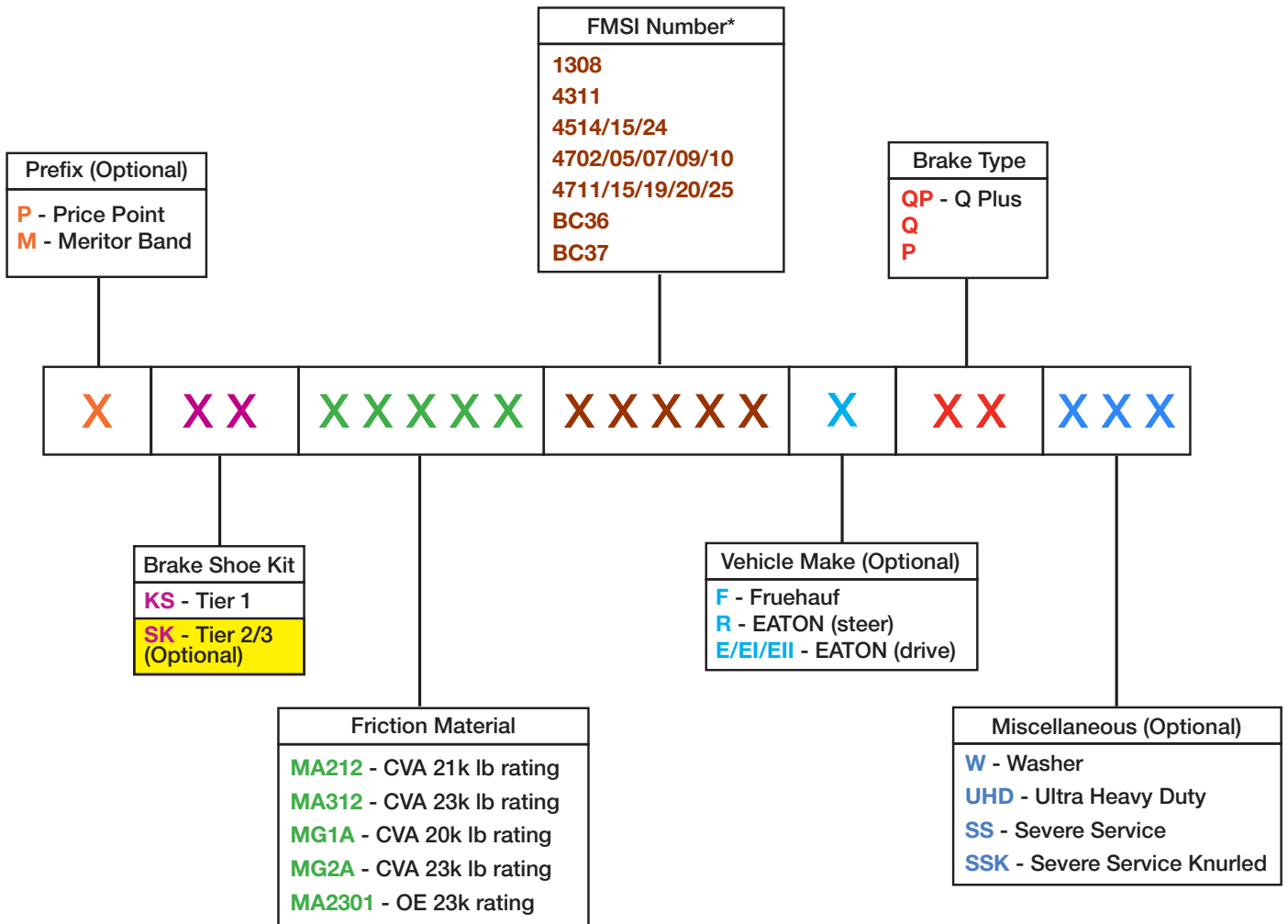

***Notes**

- FMSI - Industry number that defines type of brake and brake size (e.g. 4515 = 'P' brake & 16.5" x 7" size)
- R301 and R403 friction materials have been replaced by MA2301 (R403 selected applications only; contact technical support)

Revision:		
A	15FEB21	ORIGINAL ISSUE
B	23APR21	INITIAL RELEASE
C	01FEB23	R301 REPLACED BY MA2301
D	16MAR23	NOTE ADDED FOR FMSI NUMBER AND REMOVED R403 FRICTION

Meritor Heavy Vehicle Systems
50 Calarco Drive, Derrimut, VIC 3026 Australia



IDENTIFICATION CHART #24-001

DIFFERENTIAL CARRIERS

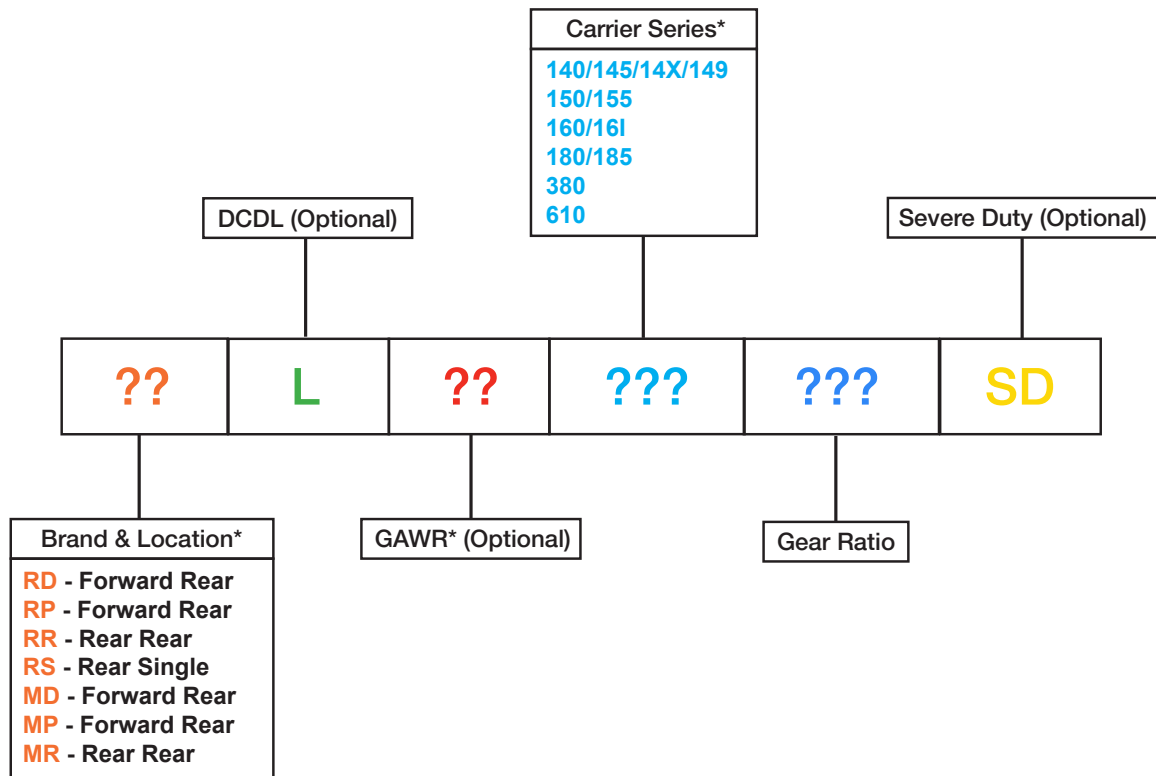

Notes:

- *Brand & Location - Legacy Rockwell ('R') part numbers have been replaced by Meritor ('M') part numbers
- *Brand & Location - MD/RD carriers are pump-less
- *GAWR - This is no longer added in the latest iteration of carrier part numbers (e.g. MR23160307 replaced by MR160307)
- *Carrier Series - P610 series is a planetary hub reduction axle application
- *SD suffix - 160 series carriers fitted with heavy duty pinion bearings; current carrier part numbers come with this feature as standard

Revision:		
A	01DEC2023	ORIGINAL ISSUE
B	01MAR2024	UPDATED IMPORTED CARRIERS
C	12APR2024	READY FOR RELEASE

Meritor Heavy Vehicle Systems
50 Calarco Drive, Derrimut, VIC 3026 Australia



Meritor Heavy Vehicle Systems Australia
50 Calaroo Drive
Derrimut, VIC 3026
AUSTRALIA

(03) 8353 6050
meritorpartsexpress.com

CMFL201 - IDENTIFICATION CHARTS 04/24
Produced in AUS 0424
©2024 Cummins Inc.